

1

2

3

4

5

JST SMR-03V-B

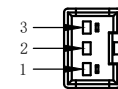
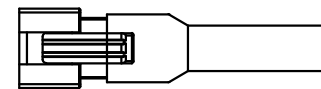

芯数 定义

1 正

2 空

3 负

延长线型号 SM24-Lx (x代表线长: 1/3/5)

unit: mm

A

B

C

D

E

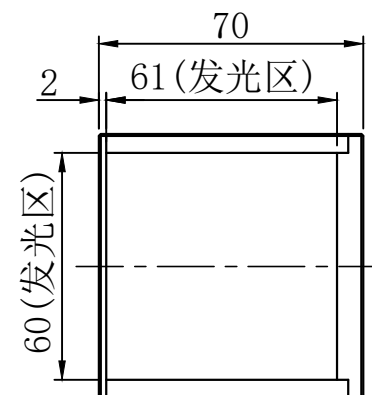
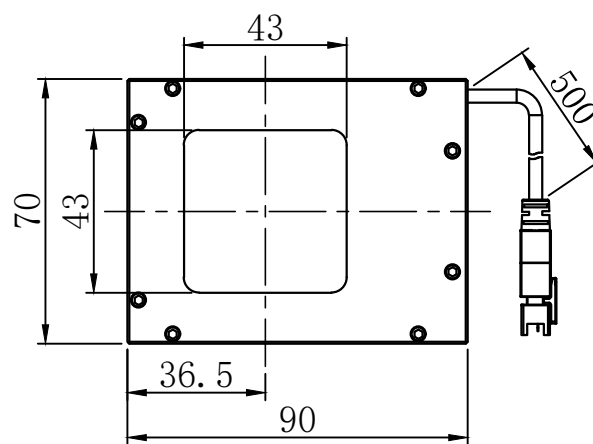
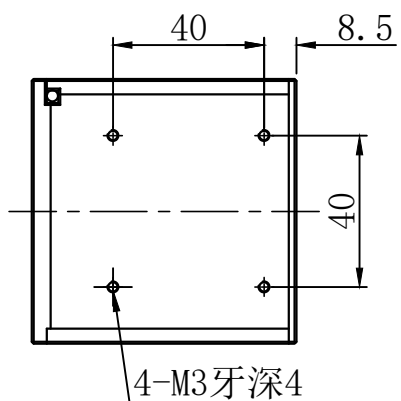

设计者	尺寸图版本号	1.0	型号	CST-COSC60	产品安装尺寸图	
曾工	日期	2022-01-07	品名	转角同轴光源		
			比例	1:2		